



An introduction to the InCrops Enterprise Hub - a perspective on the exploitation of plants for natural remedies

Dr John French
Managing Director



Innovation in Crops

- A new technology transfer project stimulating innovation in alternative and non food crops



The Vision

- InCrops
- Business
- International
- New crops
e.g. Sea Buckthorn



Interest areas

- Biorefineries
- Bioenergy
- Biocomposites
- High value extracts
- Medicinally active plants
- *Arnica montana*



Promoting innovation

- Commercialisation of alternative and non food crops
- Responding to global markets
- Levering the global research base
- Developing supply chains
- Developing a low carbon economy
- Promoting innovative companies

InCrops partnership

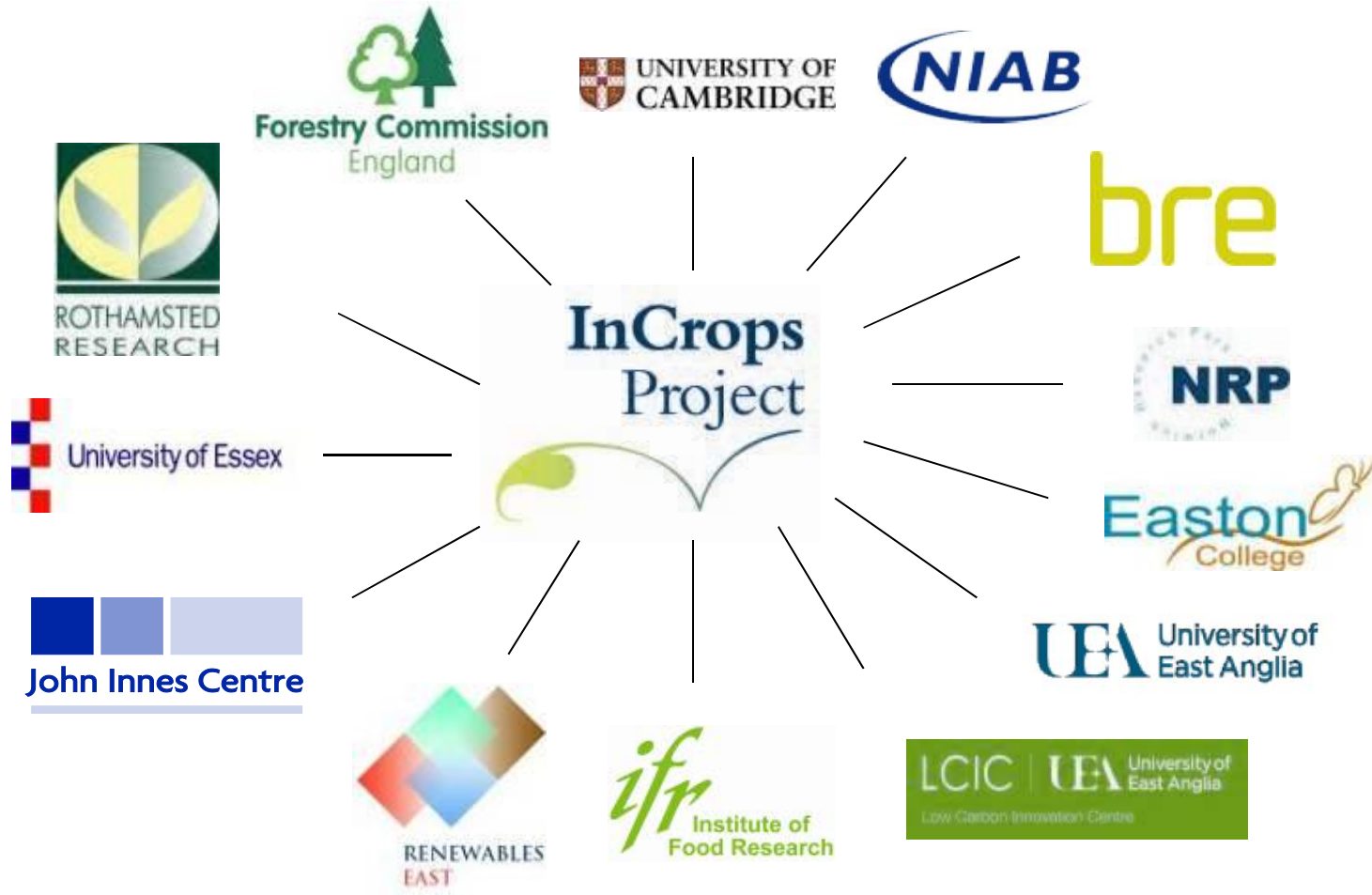

A new distributed type of enterprise hub concept

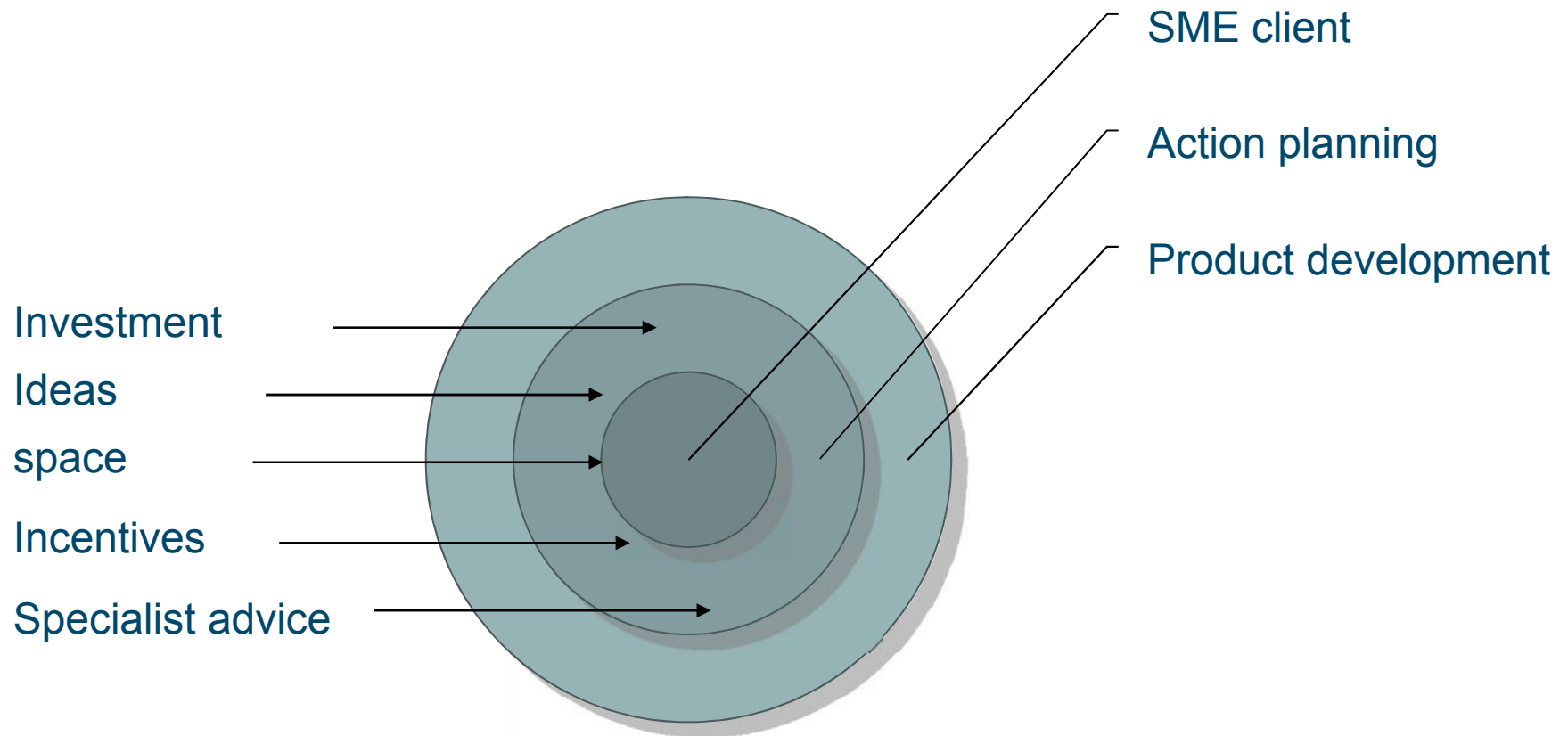

Plants and medicine

- Chinese Herbal medicine
- Indian Ayurvedic medicine
- Scientific investigation of plant bioactive compounds
- Convergence of disciplines from different continents



Investigating Medicinal herbs

<i>Adhatoda vasica</i>	vasicine	cough suppreseeant, bronchodilator
<i>Andrographis paniculata</i>	andrographolide	cold and flu, liver tonic
<i>Bacopa monneri</i>	bacosides	Memory enhancer
<i>Boswellia serrata</i>	boswellic acids	anti-inflammatory joint health
<i>Coleus forskohlii</i>	forskolin	cardiac tonic,
<i>Cinnamon cassia</i>	polyphenols	blood sugar management
<i>Curcuma longa</i>	curcumanoids	antioxidant, anti-inflammatory
<i>Garcinia cambogia</i>	Hydroxycitric acid	anti-obeisant
<i>Glyyrrhiza glabra</i>	glycyrrhizin	natural sweetener,anti-inflammatory
<i>Hedychium spicatum</i>	p-methoxyethyl cinnamate	antibacterial
<i>Mucana pruriens</i>	L-dopa	sexual heath, support in parkinsons
<i>Ocimum sanctum</i>	ursolic, oleanolic, rosmarinic acids,	anti-stress, blood sugar management
<i>Punica granatum</i>	Punicalagins	heart health, antioxidant
<i>Tribulus terrestris</i>	saponins	cholesterol lowering
<i>Withania sonifera</i>	withanolides	immune health, antistress
<i>Zingiber officinalis</i>	gingerols	heart health digestive aid,

Sustainable Agriculture (SAIN) Temperate crops (TNAU)





Promoting innovation in alternative and non-food crops
– a new science and knowledge transfer initiative
based in the East of England

